

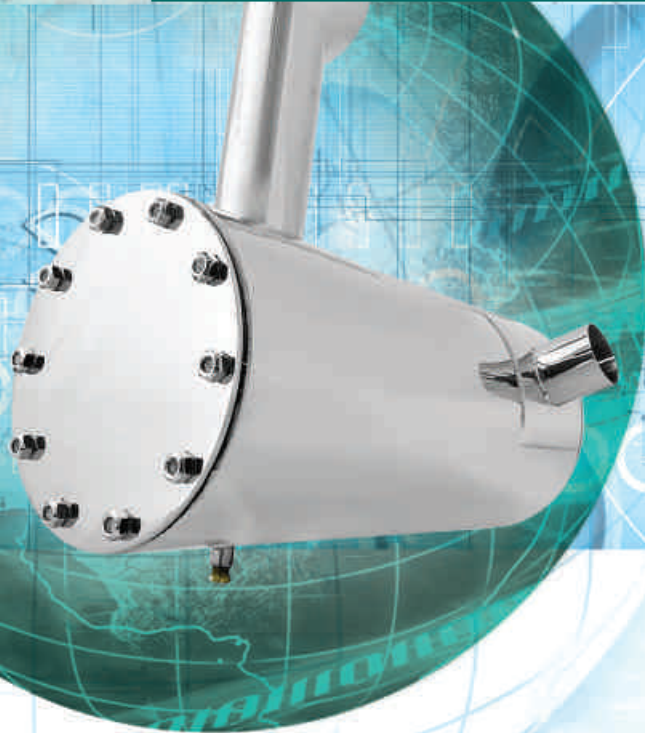

Diesel Particulate Filters

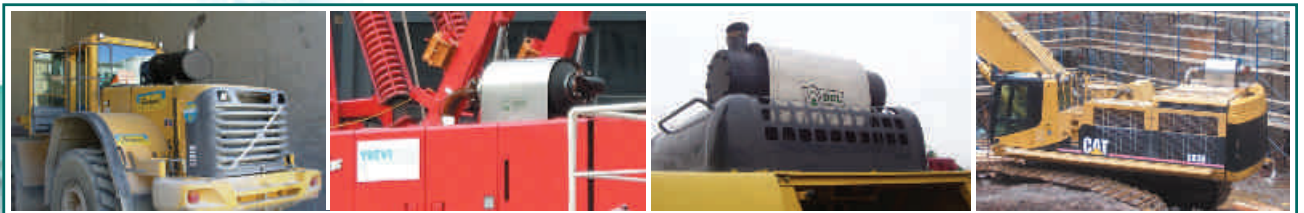

MINE-X SOOTFILTER®

Off-Road Diesel Equipment



MINE-X[®]

Making Off-Road Diesel Compliance Simple

The MINE-X SOOTFILTER[®] DPF system is one of the first California Air Resources Board (CARB) verified Level 3 passively regenerating diesel particulate filters for off-road diesel applications. The MINE-X SOOTFILTER[®] DPF system reduces emissions of diesel particulate matter by greater than 85 %.

A vehicle outfitted with a MINE-X SOOTFILTER[®] DPF can operate as normal while heat from the engine exhaust burns off the particulates in a continuous manner.

The two-stage MINE-X SOOTFILTER[®] DPF system contains a catalyzed non-blocking flow-through filter, followed by a wall-flow diesel particulate filter, and a backpressure and temperature monitoring system.



Exhaust Monitoring System

DCL's state-of-the-art exhaust monitoring system is a component of the MINE-X SOOTFILTER[®] DPF system.

- The display face is mounted in the operator's cabin and gives a clear visual status of the DPF.
- Meets CARB/EPA/VERT data logging standards.
- Contains a large memory card for keeping a long-term record of the vehicle operating conditions.
- Optional remote connectivity features (GSM, GPRS and GPS).

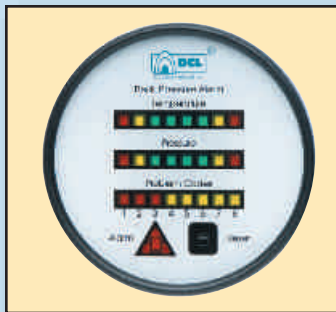

Custom Design

DCL offers direct muffler replacement DPFs for a number of vehicle models. Below is an example of a MINE-X SOOTFILTER[®] DPF muffler installed on a Caterpillar 950G Wheel Loader.



Standard Design

Externally mounted DPF designs are accompanied with an installation kit, which provides adequate support of the DPF and simplifies the installation process.



A MINE-X SOOTFILTER® DPF installed on a Caterpillar 245D Excavator

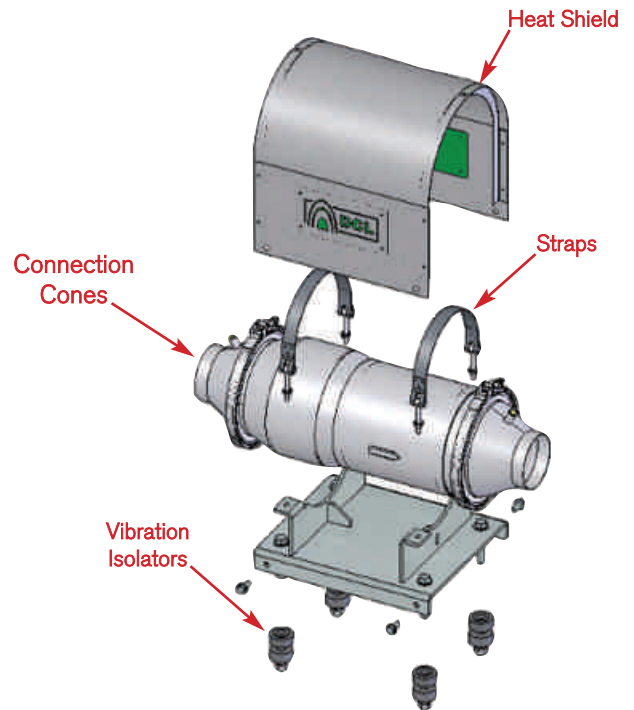

Exploded view of a MINE-X SOOTFILTER® DPF and mounting kit

Features

Benefits

CARB Level 3 verified *	Meets California In-Use Off-Road Diesel Vehicle Rule. (>85 % PM conversion efficiency; CARB NO ₂ compliant)
Passive catalytic regeneration of diesel particulates	<ul style="list-style-type: none"> ▪ Eliminates unscheduled vehicle downtime for DPF regeneration. ▪ No external power source required. ▪ No burners or electric heaters required. ▪ Lower cost of ownership.
Direct muffler replacement **	Muffler replacement designs directly replace the original muffler, for quick and easy installation.
Custom engineering	Custom designs and kits available for easy and fast installation.
Heavy gauge stainless steel construction	<ul style="list-style-type: none"> ▪ Designed for the most extreme duty applications. ▪ All designs come with flanges or quick-release clamps for easy service and ash removal.
State-of-the-art DPF monitoring system and display panel	Provides the operator with a clear visual status of the DPF condition.
Compact design	The DPF does not interfere with the operator's visibility.

* For off-road applications covered under the verification, contact the California Air Resources Board, or visit www.dcl-inc.com.

** Available for certain vehicle models.

DCL International Inc. – Preserving and Improving the Quality of the Air We Breathe

DCL International Inc. is a global leader in the engineering, manufacturing and supporting of advanced emissions control technology for stationary and mobile industrial engines. Our products – which include oxidation and three-way catalysts, silencers, particulate filters, SCR systems and accessories – are used worldwide in the material handling, construction, mining, gas compression and power generation markets.

DCL's dedicated industrial focus is unique in the emissions control industry. To meet the specialized needs of the industrial market, we adopt an integrated approach, bringing together product development, design, manufacturing and testing all under one roof. This single-source capability enables us to provide better engineered emissions solutions that deliver outstanding performance, longer life and lower cost of ownership. Our superior product quality has made DCL the choice of customers around the world.

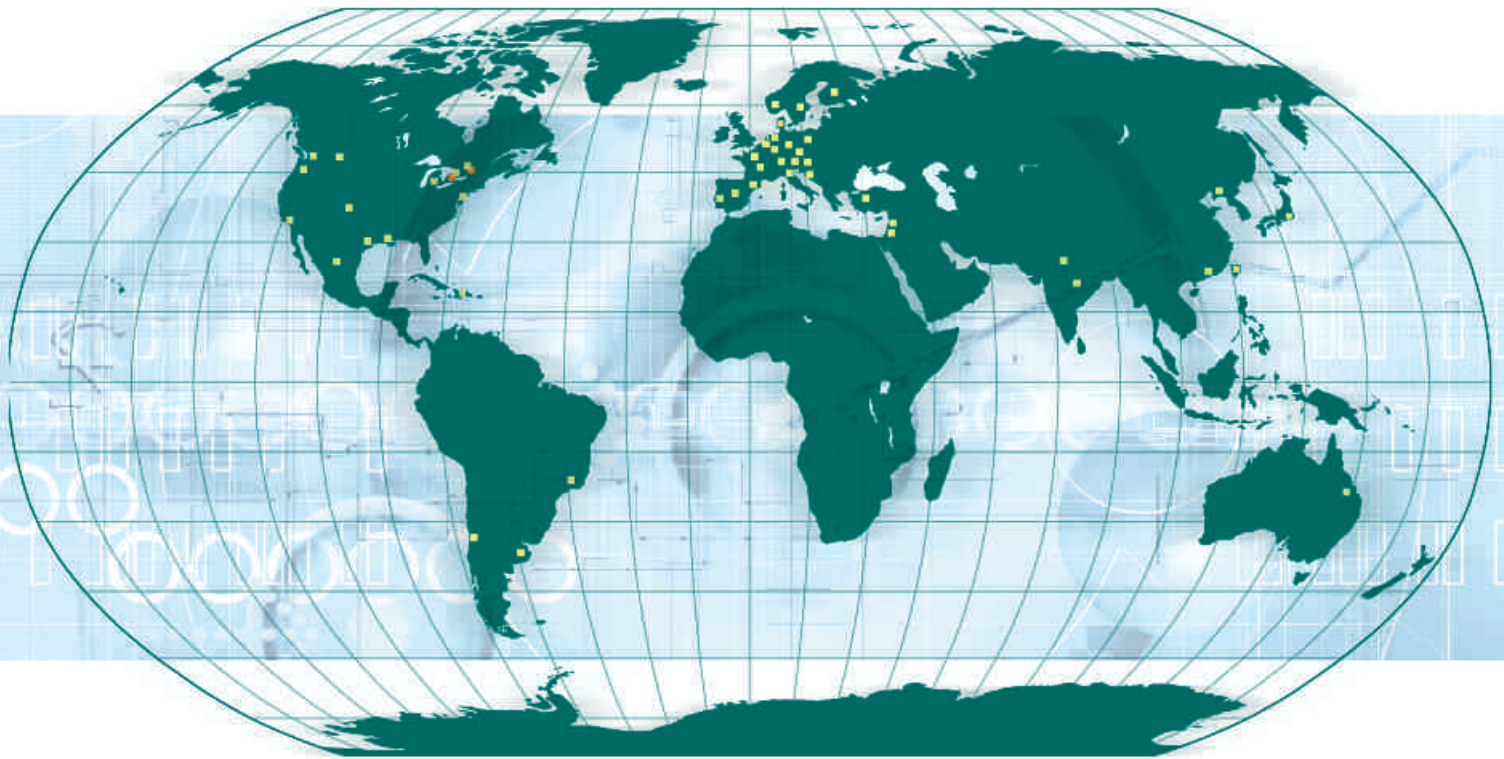

■ Manufacturing Facilities

■ Representatives



DCL International Inc.

DCL International Inc.
Corporate Headquarters
P.O. Box 90
Concord, Ontario
L4K 1B2, Canada

1-800-872-1968

Phone: (905) 660-6450
Fax: (905) 660-6435
e-mail: info@dcl-inc.com
web: www.dcl-inc.com

ISO 9001:2000 Registered